

## Lecture 18

Now that we've developed our approximation methods, we can turn to **solving the helium atom**. As usual our Schrödinger equation is  $\hat{H} \psi = E \psi$ , where

$$\hat{H} = -\frac{\hbar^2}{2m_e}(\nabla_1^2 + \nabla_2^2) - \frac{2e^2}{4\pi\epsilon_0 r_1} - \frac{2e^2}{4\pi\epsilon_0 r_2} + \frac{e^2}{4\pi\epsilon_0 r_{12}}$$

Lets **begin by applying perturbation theory** and see what we can learn from it. We are interested in particular in the ground state wavefunction. WHAT IS OUR UNPERTURBED

HAMILTONIAN? [ $\hat{H}^{(0)} = -\frac{\hbar^2}{2m_e}(\nabla_1^2 + \nabla_2^2) - \frac{2e^2}{r_1} - \frac{2e^2}{r_2} = \hat{H}_H(1) + \hat{H}_H(2)$ , where  $\hat{H}_H$  is the

Hamiltonian for a hydrogen-like atom.] WHAT IS OUR  $\psi^{(0)}$ ?

[ $\psi^{(0)}(r_1, r_2) = \psi_{1s}(1)\psi_{1s}(2)$ , where  $\psi_{1s}(1) = \frac{1}{\sqrt{\pi}} \left(\frac{Z}{A_0}\right)^{3/2} e^{-\frac{Zr_1}{A_0}}$ . The energy of an electron in

a hydrogen-like system is given by

$$E_n = -\frac{Z^2 m e^4}{2(4\pi\epsilon_0)^2 \hbar^2 n^2}$$

WHAT IS THE ENERGY OF THE GROUND STATE OF OUR UNPERTURBED SYSTEM?

$$E^{(0)} = E_{1s}(1) + E_{1s}(2) = \frac{-Z^2 m e^4}{2(4\pi\epsilon_0)^2 \hbar^2 n_1^2} + \frac{-Z^2 m e^4}{2(4\pi\epsilon_0)^2 \hbar^2 n_2^2} = \frac{-4m e^4}{(4\pi\epsilon_0)^2 \hbar^2}$$

WHAT IS OUR PERTURBATION?

$$[\hat{H}^{(1)} = \frac{e^2}{4\pi\epsilon_0 r_{12}}]$$

WHAT IS THE EQUATION WE USE TO CALCULATE THE CORRECTION TO OUR ENERGY?

$$\Delta E = \int \psi^{(0)*} \hat{H}^{(1)} \psi^{(0)} d\tau = \int \psi^{(0)*} \frac{e^2}{4\pi\epsilon_0 r_{12}} \psi^{(0)} d\tau$$

When we plug in the zero order wavefunction we just worked out we get

$$\Delta E = \frac{5}{8} \frac{Zme^4}{(4\pi\epsilon_0)^2 \hbar^2}$$

So our total energy is  $E^{(0)} + \Delta E = -2.75 \frac{me^4}{(4\pi\epsilon_0)^2 \hbar^2}$ . Because this is an approximation,

we expect that this energy will differ from the true energy. In fact we find that the

experimental value for this energy is  $E_{\text{He}}(\text{exp}) = -2.9033 \frac{me^4}{(4\pi\epsilon_0)^2 \hbar^2}$ . Thus ignoring the

second order terms leads to an error of about 5%. However, just including the second

order correction improves the energy to  $-2.91 \frac{me^4}{(4\pi\epsilon_0)^2 \hbar^2}$ . Using several orders of

perturbation theory, we can improve the energy to within .01 % of the experimental

value.

Thus for Helium we can make the following observations.

- 1) The first order correction is large, not small, since  $E^{(1)} = .31 E^{(0)}$ .
- 2) The error remaining after the first order correction is about 5%.
- 3) If we go on to second order perturbation theory, the error is reduced to .2%.

**What conclusions can we draw from these observations?** The first is that **the helium wavefunction must be substantially different than the unperturbed wavefunctions** we used to calculate their energies. To see this remember that when we derived the formula for the first order correction, we assumed that we could write the energy and the wavefunction as

$$E = E^{(0)} + E^{(1)},$$

where  $E^{(1)}$  is small, and

$$\psi = \psi^{(0)} + \psi^{(1)},$$

where  $\psi^{(1)}$  is small. **Since  $E^{(1)}$  was not small, we can conclude that  $\psi^{(1)}$  was not small,** and that therefore the helium atom ground state wavefunction is substantially different than two electrons in hydrogen-like 1s orbitals.

Now let's turn to the **variational method**. First we write down our Hamiltonian,

$$\hat{H} = -\frac{\hbar^2}{2m_e}(\nabla_1^2 + \nabla_2^2) - \frac{2e^2}{4\pi\epsilon_0 r_1} - \frac{2e^2}{4\pi\epsilon_0 r_2} + \frac{e^2}{4\pi\epsilon_0 r_{12}}$$

Next we need to **choose a trial function**. A logical choice is to **use the product of two hydrogen-like 1s orbitals**, since this would correspond to putting one electron in each of these orbitals. If we write this out this gives us

$$\phi = \frac{1}{\sqrt{\pi}} \left(\frac{Z}{a_0}\right)^{3/2} e^{-\frac{Zr_1}{a_0}} \frac{1}{\sqrt{\pi}} \left(\frac{Z}{a_0}\right)^{3/2} e^{-\frac{Zr_2}{a_0}}$$

Remember that in order to use the variational principle, we need to choose a variational parameter, a parameter that we can vary in order to find the minimum energy for our trial function. For this trial function we'll **let the atomic number Z be our adjustable parameter**. Essentially what we're doing here is asking, "What if the nuclear charge that each electron sees is less than the actual charge? What will this **"effective nuclear charge"** be?"

When we **plug this trial function into our formula for the energy  $E_\phi$**  of our trial function,

$$E_\phi = \frac{\int \phi^* \hat{H} \phi d\tau}{\int \phi^* \phi d\tau}$$

we find that

$$E_{\phi} = \left( Z^2 - \frac{27}{8} Z \right) \frac{me^4}{(4\pi\epsilon_0)^2 \hbar^2}$$

When we take the derivative with respect to  $Z$ , we find that the minimum energy we get for this trial function is when  $Z = 27/16$ , and is equal to  $-2.8477 \frac{me^4}{(4\pi\epsilon_0)^2 \hbar^2}$ . This is an error of about 2%, and is a pretty good result for a first try.

Remember that we said that when we allow  $Z$  to vary, we are treating it as an **effective nuclear charge**. The effective charge we calculated  $27/16 = 1.69$ , is substantially smaller than the actual nuclear charge of two. What does it mean for the nucleus to have an effective charge smaller than its actual charge? It means that the force that the nucleus exerts on the electron corresponds to that smaller charge. To see why this makes sense let's consider a picture of a helium atom. At any given time we have two electrons in the vicinity of the nucleus at

two different radii,  $r_1$  and  $r_2$ . In most positions of the electrons, they will both feel the full charge of  $+2$  from the helium nucleus. Now suppose that the two electrons are lined up. The electron at  $r_1$  sees the full charge of the nucleus, but the electron at  $r_2$  sees only a charge

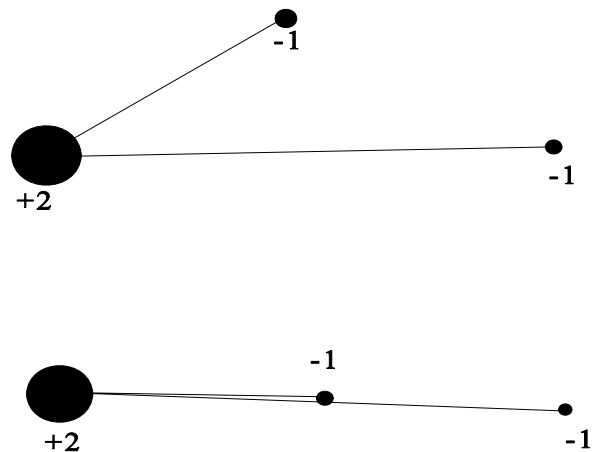

of  $+1$  because the other electron effectively cancels part of the charge. We say that **the first electron partially screens the second electron from the nucleus**. The reduced effective charge reflects the fact that there are a number of positions where one electron can screen the nucleus for the other.



## Lecture 19

Now I'd like to move along in the periodic table and calculate the **ground state energy of lithium**. When we started to do this for helium, we began with a trial function which put both electrons in 1s orbitals,  $\phi_{\text{He}} = \phi_{1s}(1)\phi_{1s}(2)$ . It would seem reasonable to extend this to lithium and to say that its ground state consists of three electrons in 1s orbitals,  $\phi_{\text{Li}} = \phi_{1s}(1)\phi_{1s}(2)\phi_{1s}(3)$ . We all know that we can't have three 1s electrons in the same atom. However, nothing we've developed at this point precludes such a ground state. To understand why such a ground state cannot exist, we need to introduce a new physical property, the electron spin, and a new postulate of quantum mechanics, the Pauli Exclusion Principle.

The evidence for this new property, the so-called **electron spin**, came unexpectedly in an experiment performed in 1922 by Otto Stern and Walter Gerlach. In their experiment, they measured the magnetic states of silver atoms by passing a beam of silver atoms through a magnetic field. What did they expect to see? First realize that the magnetic field will interact only with the magnetic moments of the atoms. Thus any effect of the magnetic field on the beam of atoms will be as a result of this magnet-magnet interaction.

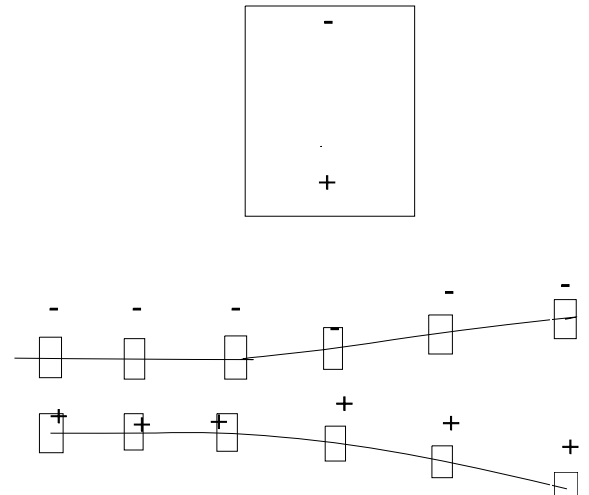

What happens if we pass a moving magnet through a magnetic field? Suppose our magnetic field,  $B$ , is caused by a permanent magnet. Such a magnet has two poles, a positive pole and a negative pole. We'll put our magnet with the positive pole facing

downward. Suppose that the traveling magnet has its negative pole facing upward. When it interacts with the B field from the permanent magnet, it will be attracted, so its path will be deflected upward.

What if its positive pole is facing upward? Because identical poles are interacting, the traveling magnet will be repelled and the beam will be deflected downward. The size of the deflection depends on the orientation of the magnet passing through the field. The attraction of two magnets is maximized when the positive and negative poles point directly at each other, and thus the upward deflection is maximized for this case. The repulsion is maximized when the two positive poles point directly at each other, and thus the downward deflection is maximized for this case. If the poles of the two magnets are at right angles to each other, there is no repulsion or attraction at all, and no deflection. If the traveling magnet is pointing so its positive pole is somewhere between perpendicular and pointing directly at the other magnet, then the attraction will be somewhere between 0 and the maximum, and there will be a deflection somewhat less than the maximum.

What do we expect to see for a beam of silver atoms? The beam of atoms can be prepared so that all of the atoms are characterized by the same angular momentum  $L = \hbar(l(l+1))^{1/2}$ . This angular momentum state determines the strength of the atom's magnetic moment. **The larger  $l$  is, the stronger the magnet is.** For every  $l$  there are  $2l + 1$  values of  $m$ . These  $m$  values tell us which way the magnet is pointing. An  $m$  value of  $+l$  will have the positive pole of the magnet as close as possible to the positive pole of the field, so we will have the maximum downward deflection of the beam of atoms. All other positive  $m$  values will also result in a downward deflection, but to a lesser degree.

If the  $m$  value is zero, the magnet will be perpendicular to the magnetic field, and there will be no deflection. Finally if the  $m$  value is negative, the negative pole of the magnet will be facing the magnetic field, and the deflection will be upward. The closer  $m$  is to  $-l$ , the stronger the deflection will be.

Lets predict what will happen to the beam if the atoms are prepared so that all of them have  $l = 0$ ,  $l = 1$ , and  $l = 2$ . If  $l = 0$ , there is only one  $m$  value, 0, and when the beam passes through the magnetic field it will be undeflected. When  $l = 1$  we have three possible  $m$  values,  $m = -1, 0, 1$ . Those

atoms with  $m = 1$  will be deflected downward, those atoms with  $m = 0$  will be undeflected, and those atoms with  $m = -1$  will be deflected upward. Thus a beam of atoms with  $l = 1$  will be split into three beams when it passes into a magnetic field. Lets consider  $l = 2$ . WHAT ARE THE POSSIBLE M VALUES? WHAT WILL HAPPEN TO A BEAM OF ATOMS WITH  $L = 2$  WHEN THEY PASS THROUGH THE MAGNETIC FIELD?

So what did Stern and Gerlach actually see? **When they passed their beam of silver atoms through the magnetic field it split into two components.** From our analysis above, we know that this can't be due to an  $l = 0$  state which would leave the

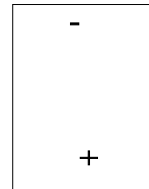

$l = 0$

$l = 1$

$l = 2$

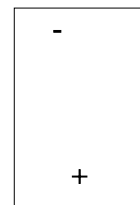
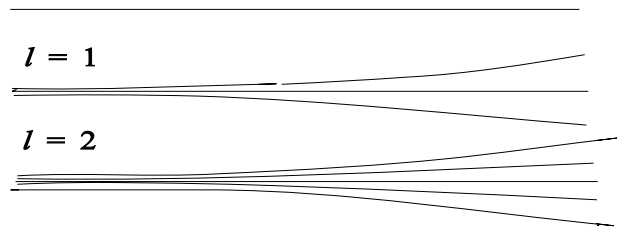

Ag atoms

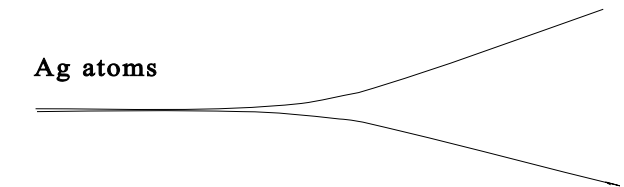

**Stern Gerlach Experiment**

beam completely undeflected, or to an  $l = 1$  state which would split the beam into three components. Remember that there are  $2l + 1$  m states for each value of  $l$ . We can use this to figure out the value of the angular momentum quantum number that leads to this strange behavior. Since we have two components, we can write

$$2 = 2l + 1$$

and therefore  $l = 1/2$ . This has to be due to a new property since we already know that the  $l$  quantum number, which determines orbital angular momentum, is limited to the values  $l = 0, 1, 2, \dots$ . Yet **this new property must be due to some kind of angular momentum**, since a magnetic moment results.

In 1925, Wolfgang Pauli explained this behavior by postulating that an electron could exist in two states. To label these states, Pauli postulated the existence of a fourth quantum number,  $m_s$ , which we now call the **spin quantum number**. This spin quantum number can only take on the values  $m_s = 1/2$  or  $-1/2$ .

When Pauli introduced this quantum number, he had not yet given it an interpretation. It was George Uhlenbeck and Samuel Goudsmit of the University of Leiden who identified these quantum numbers with angular momentum states of the electron. They are called spin states because they have the same magnitude no matter how fast the electron is traveling, so this can't be due to orbital motion. If the electron were a classical object the only source of angular momentum other than orbital motion would be spinning, top like motions, hence the name spin. We should be cautioned, however, against taking the name too literally. **The electron is not actually spinning.** Rather we should view  $m_s$  as referring to the orientation of a magnetic moment intrinsic to the electron. To clarify this point, Bohr has calculated that for a spinning electron to

have the experimentally determined magnetic moment, it would have to spin at a speed many times greater than the speed of light, an impossibility. Electron spin is a purely quantum phenomenon. It has no classical analog.

The way that we've introduced the electron spin quantum number may remind you of the Bohr hydrogen atom. Remember that Bohr postulated the quantization of the orbital angular momentum rather than have it come as a solution to his equations. This is rather unsatisfactory, because it doesn't yield much in the way of physical insight. And in fact, the Schrödinger and Heisenberg formulations of quantum mechanics cannot predict the existence of the electron spin.

Fortunately for quantum mechanics, P.A.M. Dirac, in the 1930's, constructed a wave equation that combined the ideas of Schrödinger with Einstein's special relativity. This Dirac equation was immensely successful. Not only did its solution include the electron spin quantum number, but it predicted the existence of positrons before they were first observed.

**How do we deal quantitatively with electron spin** in our non-relativistic formulation of quantum mechanics? **The spin quantum number,  $m_s$ , as the Stern-Gerlach experiment showed, is an experimental observable.** According to our postulates, **any observable is the eigenvalue of an eigenvalue equation** of the form

$$\hat{A} \psi = a\psi,$$

so **we need to define appropriate wavefunctions and operators.** We take the angular momentum eigenvalue equations for the hydrogen atom,

$$\hat{L}^2 Y_l^m = \hbar^2 l(l+1) Y_l^m$$

and

$$\hat{L}_z Y_l^m = m\hbar Y_l^m$$

as our model, and define spin angular momentum operators  $\hat{S}^2$  and  $\hat{S}_z$  and spin wavefunctions  $\alpha$  and  $\beta$ . The wavefunction  $\alpha$  is characterized by the equations

$$\hat{S}^2 \alpha = \frac{1}{2} \left( \frac{1}{2} + 1 \right) \hbar^2 \alpha$$

and

$$\hat{S}_z \alpha = +\frac{1}{2} \hbar \alpha = m_s \alpha.$$

which give the spin angular momentum squared and the spin angular momentum in the z direction, so **the wavefunction  $\alpha$  corresponds to an electron spin of 1/2.** The wavefunction  $\beta$  is characterized by the eigenvalue equations

$$\hat{S}^2 \beta = \frac{1}{2} \left( \frac{1}{2} + 1 \right) \hbar^2 \beta$$

and

$$\hat{S}_z \beta = -\frac{1}{2} \hbar \beta = m_s \beta.$$

so **the wavefunction  $\beta$  corresponds to an electron spin of -1/2.** Note that **it is only the  $\hat{S}_z$  operator that distinguishes between these two eigenfunctions.** The angular momentum of both states is the same, and is equal to

$$S = \hbar \sqrt{s(s+1)} = \hbar \sqrt{3/4}$$

**The  $\hat{S}_z$  operator, which distinguishes the two wavefunctions, corresponds to the orientation of the spin angular momentum relative to the z axis.**

Note that **there is only one magnitude of the spin quantum number.** Remember that for problems like the harmonic oscillator or the rigid rotator, the

wavefunction takes on classical behavior when the quantum number gets large. **Since the spin quantum number is limited to 1/2, it can never become large and electron spin can never behave classically.** To reiterate, electron spin is a purely quantum phenomenon.

The final part of our definition of the spin wavefunctions is to state that **the spin eigenfunctions  $\alpha$  and  $\beta$  are orthonormal**, i.e., that we can write

$$\int \alpha^* \alpha d\sigma = \int \beta^* \beta d\sigma = 1$$

and

$$\int \alpha^* \beta d\sigma = \int \beta^* \alpha d\sigma = 0$$

where  $d\sigma$  is called the spin variable, which again has no classical analog.

We now can see **how to combine these spin wavefunctions with our spatial wavefunctions**. The wavefunction will be a function of four variables, the usual spatial variables,  $r$ ,  $\theta$ ,  $\phi$ , and our new variable, the spin variable  $\sigma$ , so we write

$$\psi_{nlm m_s} = \psi_{nlm m_s}(r, \theta, \phi, \sigma)$$

Notice that the wavefunction is now labeled by four quantum numbers, the three spatial quantum numbers,  $n$ ,  $l$  and  $m$ , and the new spin quantum number,  $m_s$ . This means that to be completely described, **each wavefunction must contain some value of each of these four quantum numbers**.

We've already noted that this new property of electron spin is a strange one, very unlike the other dynamical properties we've studied, so it seems reasonable that it would be independent of other variables. This is another way of saying that it should be separable, so we'll postulate this and **write the complete wavefunction as a product of**

a **spatial wavefunction, like our hydrogen-like orbitals, and a spin function.** For a wavefunction with  $m_s = 1/2$ , we have  $\psi_{nlm\frac{1}{2}} = \psi_{nlm}(r, \theta, \phi)\alpha(\sigma)$ , and for a wavefunction with  $m_s = -1/2$ , we have  $\psi_{nlm-\frac{1}{2}} = \psi_{nlm}(r, \theta, \phi)\beta(\sigma)$ . These complete one electron wavefunctions are called **spin orbitals**. As an example, the 1s orbital is the ground state spatial orbital of a hydrogen-like atom. The first two spin orbitals of the hydrogen-like atom are

$$\psi_{100\frac{1}{2}} = \left(\frac{Z^3}{a_0^3\pi}\right)^{1/2} e^{-\frac{Zr}{a_0}} \alpha$$

and

$$\psi_{100-\frac{1}{2}} = \left(\frac{Z^3}{a_0^3\pi}\right)^{1/2} e^{-\frac{Zr}{a_0}} \beta.$$

These spin orbitals are normalized and orthogonal.

**Lecture 20**

Since the electron spin was first discovered because atoms showed an unexpected response to a magnetic field, it is logical that **the energy of spin wavefunctions in a magnetic field will depend on the value of the electron spin quantum number**. Let's work out this energy difference.

The **magnetic moment of the electron is proportional to the spin angular momentum** and is given by

$$\mu_s = -\frac{g_e e}{2m_e} S$$

This is identical to the equation for the orbital magnetic moment, with the exception of the constant  $g_e$ , called the electron  $g$  factor and equal to 2.002322. The important part of the magnetic moment is the  $z$  component, given by

$$\mu_z = -\frac{g_e}{2m_e} S_z$$

$S_z$  is the component of the spin angular momentum in the  $z$  direction and is equal to  $m_s \hbar$ .

This means that we can rewrite the magnetic moment as

$$\mu_z = -\frac{g_e e \hbar}{2m_e} m_s = -g_e \mu_B m_s$$

The classical potential energy when we place this electron in a magnetic field of strength  $B$  is

$$V = g_e \mu_B m_s B$$

If we add this term to the Hamiltonian for a hydrogen atom in a magnetic field, our new Hamiltonian including electron spin becomes

$$\hat{H} = \hat{H}_0 + \frac{eB}{2m_e}(\hat{L}_z + g_e\hat{S}_z).$$

where  $\hat{H}_0$  is the Hamiltonian for a hydrogen atom in the absence of an external field.

The energy eigenvalues now depend on three quantum numbers,  $n$ ,  $m$ , and  $m_s$ , and are now given by

$$E_{nlm m_s} = -\frac{me^4 Z^2}{2(4\pi\epsilon_0)^2 \hbar^2 n^2} + \frac{eB\hbar}{2m_e}(m + g_e m_s).$$

Note that **the result of this new magnetic moment is to further split the hydrogen atom energy states.** Consider a 2s orbital first. There is no effect on the energy due to the orbital angular momentum, but the presence of the spin angular momentum splits the state into two distinct energy levels.

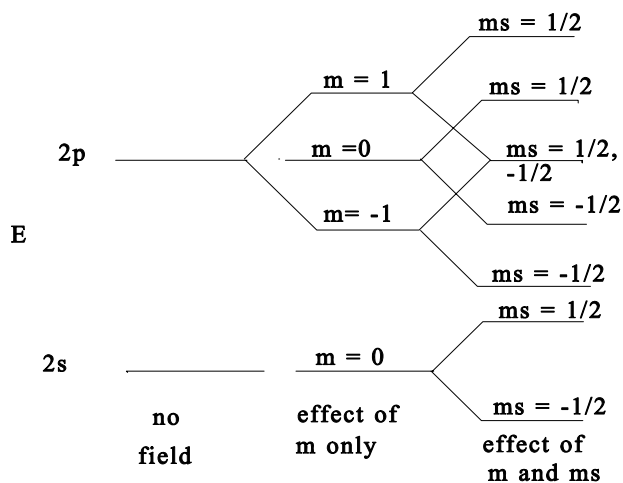

Now consider a 2p orbital. In the absence of an external field the six 2p spin orbitals are degenerate. Adding the effect of the orbital magnetic moment has the effect of splitting these into three energy levels for  $m = 1$ , 0 and -1. Finally adding the effect of the electron spin splits each of these  $m$  values into two more distinct energies. Note that although the state with  $m = 1$  and  $m_s = -1/2$  appears to have the same energy as the state with  $m = -1$  and  $m_s = +1/2$ , because the  $g$  factor is not exactly 2, these states have energies that are close to identical, but not exactly identical. Such a situation is described as near degeneracy. Near degeneracy is important in crystal field theory, where weak ligand fields will split d-orbitals in two groups of two and three orbitals with different

energies. However, the occupancy of these orbitals will still be the same as for normal d-orbitals because the splitting is small compared to the thermal energies of the electrons.

When we introduced this new property of electrons, the spin, we claimed that it would allow us to eliminate a ground state for the lithium atom in which all three electrons were in the 1s orbital. To accomplish this, the electron spin by itself is not sufficient - we need to add a new postulate, the **Pauli Exclusion Principle**. In freshman chemistry, this is usually stated as “**No two electrons in an atom can have the same values of all four quantum numbers, n, l, m, and m<sub>s</sub>.**”

This statement immediately helps us find ground state electron configurations. For example, the lithium atom has three electrons. The first electron will go into the orbital  $\psi_{100\frac{1}{2}} = 1s\alpha$ . The second electron will go into the orbital  $\psi_{100-\frac{1}{2}} = 1s\beta$ . The third electron can't go into the 1s orbital or one of the quantum numbers would have to be repeated. Thus for the third electron, we need to go to the next lowest orbital,  $\psi_{200\frac{1}{2}} = 2s\alpha$ .

So you see that **invoking this version of the Pauli exclusion principle results in a limitation of two electrons in a given orbital**, and gives rise immediately to the bulk of the form of the periodic table. Unfortunately, **the ground state wavefunction for lithium which this version of the exclusion principle predicts,  $\psi_{\text{Li}} = 1s\alpha 1s\beta 2s\alpha$** , has implications which are not supported by experiment. To obtain a more correct ground state wavefunction we need to turn to a more fundamental form of the exclusion principle, which helps us to determine the **form** of multielectron wavefunctions as well. We will present this form of the Pauli exclusion principle as a sixth postulate of quantum

mechanics, but first we need to introduce a new idea, that of an antisymmetric wavefunction.

To define what an **antisymmetric wavefunction** is let's go back to the helium atom. Using the arguments we just used for lithium, we can write the ground state wavefunction of helium as

$$\psi(1,2) = 1s\alpha(1) 1s\beta(2).$$

In other words, we put electron 1 in a  $1s\alpha$  orbital, and we put electron 2 in a  $1s\beta$  orbital. However, **there's a problem with this because it implies that our two electrons are distinguishable**, i.e., that there's some way to tell them apart. In other words, we could write another ground state wavefunction,

$$\psi(2, 1) = 1s\alpha(2) 1s\beta(1)$$

Again, this implies that electrons 1 and 2 are distinguishable, because we are saying that we can tell which electron is in which spin state. This is not the case. Remember, that nothing in quantum mechanics is meaningful unless it is ultimately linked to an observable, and even if we had a microscope with sufficient resolution, we wouldn't see any label on the electrons telling us which was electron 1 and which was electron 2. Unfortunately, this is not just a philosophical problem, because if we use our ground state wavefunction, as written above, as a variational trial function, the energies come out all wrong. **What we need to do is find a way to write the wavefunction so that it places an electron each in the  $1s\alpha$  and  $1s\beta$  orbitals, and not specific electrons in each orbital.**

**We do this by defining two new ground state wavefunctions that are linear combinations of the two above,**

$$\psi_1(1,2) = \psi(1,2) + \psi(2,1) = 1s\alpha(1) 1s\beta(2) + 1s\alpha(2) 1s\beta(1)$$

and

$$\psi_2(1,2) = \psi(1,2) - \psi(2,1) = 1s\alpha(1) 1s\beta(2) - 1s\alpha(2) 1s\beta(1).$$

**The electrons are indistinguishable in these two wavefunctions because they both contain both possible ground state configurations.** Because both configurations are included, its sort of like saying that we will always find one electron in the  $1s\alpha$  spin orbital and one in the  $1s\beta$  spin orbital without specifying which is which.

**These two orbitals are not identical.** To see the difference lets interchange electrons 1 and 2 for each of them. For  $\psi_1$ ,

$$\psi_1(2, 1) = 1s\alpha(2) 1s\beta(1) + 1s\alpha(1) 1s\beta(2) = 1s\alpha(1) 1s\beta(2) + 1s\alpha(2) 1s\beta(1) = \psi_1(1,2).$$

For this orbital, when we change the order of the electrons in the orbitals, the wavefunction remains completely unchanged. We say that **this wavefunction is symmetric to the interchange of electrons.** In contrast consider  $\psi_2$ . For this wavefunction, we have

$$\psi_2(2,1) = 1s\alpha(2) 1s\beta(1) - 1s\alpha(1) 1s\beta(2) = - (1s\alpha(1) 1s\beta(2) - 1s\alpha(2) 1s\beta(1)) = -\psi_2(1,2).$$

When we reverse the order of the electrons, the sign of the wavefunction changes. We call such a wavefunction **antisymmetric with respect to interchange of electrons.**

Now that we have defined these new terms, we are ready to state our sixth postulate, **the most complete form of the Pauli Exclusion Principle.**

### Postulate Six

**All electronic wavefunctions must be antisymmetric under the exchange of two electrons.**

According to this postulate, of the two wavefunctions that we've constructed for Helium, only the second occurs in nature. So the ground state of helium is

$$\psi_0(\text{He}) = 1s\alpha(1) 1s\beta(2) - 1s\alpha(2) 1s\beta(1).$$

Note that when we write 1s, we are not here referring to hydrogen-like 1s orbitals, but the true 1s orbitals of He, calculated by variational methods.

I know that this sixth postulate sounds strange and that it seems unconnected to physical reality, but in fact it gives rise to the Pauli exclusion principle as you learned it in general chemistry. Since we know that the Pauli exclusion principle has been experimentally verified many times over, with the structure of the periodic table being only one example, we have ample proof that this odd postulate is valid.

There is more direct evidence in support of this requirement for antisymmetric wavefunctions, and that is the nature of the first **excited states of helium**. The lowest energy wavefunction would be one in which one electron was in a 1s orbital and one in a 2s orbital. As was the case for the ground state, this can be written two different ways,

$$\psi_a(1,2) = 1s(1) 2s(2)$$

and

$$\psi_b(2,1) = 1s(2) 2s(1).$$

As in our discussion of the helium ground state, these two wavefunctions imply that the electrons are distinguishable, so we need to take linear combinations of the two, yielding

$$\psi_2(1,2) = 1s(1) 2s(2) + 1s(2) 2s(1)$$

and

$$\psi_1(1,2) = 1s(1) 2s(2) - 1s(2) 2s(1).$$

The wavefunction labeled  $\psi_1$  with an energy of -59.2 eV is lower in energy than  $\psi_2$ , with energy -58.4 eV, and thus  $\psi_1$  is the first excited state of helium.

According to the Pauli exclusion principle, the overall wavefunction, including the electron spin, must be antisymmetric. A useful fact here is that the symmetry of the product of two wavefunctions follows the rules

1) Symmetric x symmetric = symmetric

2) Antisymmetric x antisymmetric = symmetric

and 3) Antisymmetric x symmetric = symmetric x antisymmetric = antisymmetric.

Since the first excited state wavefunction without the spin is antisymmetric, the spin functions that we add must be symmetric. There are three possible symmetric spin functions that we can consider,  $\alpha(1) \alpha(2)$ , in which both electrons have spin up,  $\beta(1) \beta(2)$ , where both electrons have spin down, and  $(\alpha(1) \beta(2) + \beta(1) \alpha(2))$  the symmetric state where both electrons have opposite spins. Thus there are three different antisymmetric wavefunctions for this first excited state,

$$\psi_{1a}(1,2) = 2^{-1/2} (1s(1) 2s(2) - 1s(2) 2s(1)) \alpha(1) \alpha(2)$$

$$\psi_{1b}(1,2) = 2^{-1/2} (1s(1) 2s(2) - 1s(2) 2s(1))(\alpha(1) \beta(2) + \beta(1) \alpha(2))$$

and

$$\psi_{1c} = 2^{-1/2} (1s(1) 2s(2) - 1s(2) 2s(1)) \beta(1) \beta(2).$$

Thus the first excited state of helium in the absence of external fields is triply degenerate. Because there are three different states with the same spatial wavefunction and the same energy, we call this a **triplet state**. The difference between these states is the orientation of the angular momentum vector, so we should be able to observe a difference in energies when the helium atom is placed in a magnetic field. As expected the first excited state splits into three states with different energies, with  $\psi_{1a}$  having the highest energy,  $\psi_{1b}$  having the intermediate energy, and  $\psi_{1c}$  having the lowest energy.

What about  $\psi_2(1,2)$ , the second excited state of helium? Remember that its spatial wavefunction is symmetric. To get an overall antisymmetric wavefunction including spin, we need to multiply by an antisymmetric spin wavefunction. The only

antisymmetric spin wavefunction for two electrons is  $(\alpha(1)\beta(2) - \beta(2)\alpha(1))$ . Thus there is only one wavefunction, including spin, for the second excited state of He,

$$\psi_2(1,2) = (1s(1)2s(2) + 1s(2)2s(1))(\alpha(1)\beta(2) - \beta(2)\alpha(1)).$$

Since there is only one wavefunction that has the energy of the second excited state, the state is singly degenerate, and we call it a **singlet state**. Thus in addition to the structure of the periodic table, our sixth postulate allows us to correctly predict the triplet and singlet natures of the first two excited states of helium.